

ROUTINE

MWO effective date is 3 January 2006 and completion date is 3 January 2010.

MWO 5-2350-262-35-2

MODIFICATION WORK ORDER

MODIFICATION OF ARMORED COMBAT EARTHMOVER (ACE), M9

(NSN 2350-00-808-7100) (EIC ASA)

SYSTEM IMPROVEMENT PLAN (SIP)
PHASE 4 BLOCK MODIFICATION

HEADQUARTERS, DEPARTMENT OF THE ARMY, WASHINGTON, D.C.

3 January 2006

REPORTING ERRORS AND RECOMMENDING IMPROVEMENTS

You can help improve this MWO. If you find any mistakes or if you know of a way to improve the procedures, please let us know. Mail your DA Form 2028, (Recommended Changes to Equipment Technical Publications), through the Internet, on the Army Electronic Product Support (AEPS) website. The Internet address is <https://aeps.ria.army.mil>. The DA Form 2028 is located under the Public Applications Section in the AEPS Public Home Page. Using this form on the AEPS will enable us to respond quicker to your comments and better manage the DA Form 2028 program. You may also mail, fax, or email your letter or DA Form 2028 direct to: AMSTA-LC-LMIT/TECH PUBS, TACOM-RI, 1 Rock Island Arsenal, Rock Island, IL 61299-7630. The email address is TACOM-TECH-PUBS@ria.army.mil. The fax number is DSN 793-0726 or Commercial (309) 782-0726.

DISTRIBUTION STATEMENT A. Approved for public release; distribution is unlimited.

MODIFICATION WORK ORDER
No. 5-2350-262-35-2

HEADQUARTERS
DEPARTMENT OF THE ARMY
Washington, D.C., 3 January 2006

Modification Work Order
Modification of
Armored Combat Earthmover (ACE), M9
(NSN 2350-00-808-7100) (EIC ASA)

SYSTEM IMPROVEMENT PLAN (SIP)
PHASE 4 BLOCK MODIFICATION

TABLE OF CONTENTS

		Page
CHAPTER 1	INTRODUCTION	1-1
CHAPTER 2	CREW COOLING SYSTEM INSTALLATION.....	2-1
Section I	MWO Parts List	2-1
Section II	Tools Required	2-2
Section III	Modification Procedures.....	2-3
Section IV	System Charging & Purging Procedures.....	2-17
CHAPTER 3	CREW COOLING SYSTEM INSTALLATION FOR FORCE XXI BATTLE COMMAND-BRIGADE AND BELOW (FBCB2) EQUIPPED VEHICLES ONLY	
Section I	Modification Procedures.....	3-1

Distribution Statement A: Approved for public release; distribution is unlimited.

CHAPTER 1 INTRODUCTION

1-1 PURPOSE.

The purpose of this Modification Work Order is to improve the performance capabilities of the M9 ACE through vehicle modification and improved hardware.

1-2 PRIORITY.

This modification is classified ROUTINE.

1-3 END ITEM TO BE MODIFIED.

Nomenclature	NSN	Part Number	CAGEC	Model Number	Serial Number
Armored Combat Earthmover (ACE), M9	2350-00-808-7100	TA13211E8600	19207	M9 ACE	All

1-4 COMPONENTS TO BE MODIFIED.

Not applicable.

1-5 PARTS TO BE MODIFIED.

See applicable chapter.

1-6 APPLICATION.

- a. Time compliance schedule: MWO effective date is 3 JANUARY 2006 and completion date is 3 January 2010.
- b. The lowest level of maintenance authorized to apply this MWO: Direct Support (DS).
- c. Work Force/Skills and hour requirements for application of this MWO to a single unit, end item, or system are as follows:

REQUIREMENTS

WORK FORCE/SKILLS	MAN-HOURS
Construction Equipment Repair (62B10)	
1. Crew Cooling System (CCS) Installation.	6.0
2. Remove and Discard Microclimatic Cooling System (MCS) and Install Original Nuclear Biological Chemical (NBC) System.	10.0

MWO 5-2350-262-35-2

NOTE

Total hours to perform one CCS installation of this MWO is 6 hours.

Total hours to perform one MCS removal and one CCS and NBC system installation of this MWO is 16 hours.

- d. MWOs to be applied prior to or concurrently with the application of this MWO: Not applicable.
- e. Additional information deemed necessary to assist in the application of this MWO:

PUBLICATIONS:

AR 750-10
DA Pam 738-750

TM 750-245-4
TB 43-0209

DA Pam 738-751

1-7 TECHNICAL PUBLICATIONS AFFECTED/CHANGED.

PUBLICATIONS:

TM 5-2350-262-20-1, dated January 1997, with Change 3, dated March 2000
TM 5-2350-262-20-2, dated January 1997, with Change 3, dated March 2000
TM 5-2350-262-24P, dated March 2000
TM 5-2350-262-34, dated January 1997, with Change 2, dated March 2000

1-8 MWO KITS/PARTS AND THEIR DISPOSITION.

- a. See applicable chapter for parts.
- b. Bulk and Expendable Material are as follows:

Part No.	CAGE	NSN	Description	Qty
4700	38921	1680-01-509-4762	Charge/Purge Kit – MCU Cooling	A/R
MIL-P-83800	81349	6810-01-181-7121	Propylene Glycol, Gallon	A/R

- c. Return removed (no longer required) parts to unit for disposition.

1-9 SPECIAL TOOLS; TOOL KITS; JIGS; TEST, MEASUREMENT, AND DIAGNOSTIC EQUIPMENT (TMDE); AND FIXTURES REQUIRED.

See applicable chapter for tools/kits.

1-10 MODIFICATION PROCEDURES.

See applicable chapter for modification procedures.

1-11 CALIBRATION REQUIREMENTS.

Not applicable.

1-12 WEIGHT AND BALANCE DATA.

Weight and balance are not significantly affected.

1-2

1-13 QUALITY ASSURANCE REQUIREMENTS.

- a. General. Quality assurance will be accomplished in accordance with TM 750-245-4.
- b. Physical Inspection. Check components that are removed or installed during the modification for stability of mounting.
- c. Functional Inspection. Start vehicle and insure that vehicle is operating properly, in accordance with TM 5-2350-262-10.

1-14 RECORDING AND REPORTING OF THE MODIFICATION.

- a. Reporting Requirement. The organization responsible for MWO application will report application information as follows:

(1) Reporting will be accomplished by electronic means. MWO application information can be input directly in the Modification Management Information System (MMIS) over the Internet. Entry into the MMIS system is password protected. New users can register on-line at <https://www.mmis.army.mil>. Passwords are normally approved and issued within 48 hours.

(2) Submission will be comprised of the nine (9) data elements listed in the Table below. Elements 1, 2, & 8 are given for this MWO (as shown). The person reporting the MWO data will acquire the remaining elements 3, 4, 5, 6, 7 & 9 and input all nine into MMIS.

<u>DATA ELEMENT</u>	<u>INPUT DATA</u>
1. Materiel Change Number (MCN)	1-04-05-0009
2. MWO Number	MWO 5-2350-262-35-2
3. Unit Identifier Code	
4. NSN of the End Item	
5. Serial Number	
6. USA Registration Number	
7. Date of Application	
8. Hours Required for Application	6 or 16
9. Applied by: (Name)	

(3) If you do not have access to the Internet, recording will be on a 3.5 inch disk (or CD), which will be mailed to the MMIS administrator to the following address:

Commander
 U.S. Army Tank-automotive and Armaments Command
 6501 E. 11 Mile Road
 ATTN: AMSTA-LC-LMIM/MS 419
 Warren, MI 48397-5000

- b. Records and Reports. Record the modification in accordance with AR 750-10, DA Pam 738-750, and DA Pam 738-751.
- c. Marking Equipment. Stamp "MWO 35-2" on existing vehicle data plate 13214E2452.

1-15 MATERIEL CHANGE (MC) NUMBER.

This Modification Work Order is authorized by MC number 1-04-05-0009.

1-16 MODIFICATION IDENTIFICATION.

See applicable chapters.

CHAPTER 2 CREW COOLING SYSTEM INSTALLATION

SUBJECT: Installation of new configuration Crew Cooling System (CCS).

DATE: 3 JANUARY 2006.

DESCRIPTION: For vehicles with the Microclimatic Cooling System (MCS) installed, remove and discard the MCS and all associated hardware, power supply and distribution equipment. Install the original configuration Nuclear Biological Chemical (NBC) system. Install a new configuration CCS, consisting of a Microclimatic Cooling Unit (MCU), Hose Assembly (Coolant Umbilical), a Crew Cooling Garment (Vest) and all associated wiring harnesses and hardware.

TM REFERENCES: The technical manual references in this procedure are: TM 5-2350-262-20-1 and 2, dated January 1997 and TM 5-2350-262-24P, dated March 2000.

SECTION I MWO PARTS LIST

Table 2-1. Crew Cooling System Mounting Kit Parts List.

Part No.	CAGE	NSN	Description	Qty
12475720	19207	5340-01-519-6404	Bracket, Multi Angle, MCU Mounting	1
10917219	19207	5310-00-815-1073	Wing Nut, Self-Locking	4
12387272-41	19207	5310-01-376-3509	Washer, Lock	8
12387272-42	19207	5310-01-376-3508	Washer, Lock	4
12387272-46	19207	5310-01-378-7789	Washer, Lock	4
12387277-262	19207	5310-01-378-7694	Nut, Plain Hexagon	8
12387279-14	19207	5310-01-380-2650	Washer, Flat	12
12387301-230	19207	5305-01-379-8431	Screw, Machine, Pan Head	8
12387301-246	19207	5305-01-375-7356	Screw, Machine, Pan Head	4
12387305-9	19207	5310-01-378-8180	Nut, Plain Hexagon	4
12475721	19207	5340-01-519-6407	Bracket, Angle, MCU Base	1
12475722	19207	5340-01-519-6405	Bracket, Angle, MCU Support	1
12475723	19207	5340-01-519-6406	Bracket, Angle, MCU Top	1
12475724	19207	5340-01-519-7314	Cover, MCU Access Welded	1
MS35338-103	80205	5310-00-184-8971	Washer, Lock	1
B1821BH025C700N	80204	5305-01-519-7334	Screw, Cap, Hexagon Head	4
B1821BH038F100N	80204	5305-00-269-3240	Screw, Cap, Hexagon Head	4
B1821BH038C150N	80204	5305-00-725-2317	Screw, Cap, Hexagon Head	4
ME100-4-T	81860	5340-01-519-7354	Mount, Resilient, General Shock	4
12475737	19207	5340-01-519-6805	Bracket, Angle, Umbilical Guard	1
12475741	19207	5340-01-519-6809	Plate, Mounting, Umbilical Grommet	1
12475751	19207	5340-01-519-6810	Bracket, Angle, Umbilical BCA	1
12491610	19207	6150-01-519-7424	Wiring Harness, MCU	1

Table 2-1. Crew Cooling System Mounting Kit Parts List - Continued.

Part No.	CAGE	NSN	Description	Qty
12491611-1	19207	6150-01-519-7461	Lead, Electrical, MCU Power	1
12491611-2	19207	6150-01-519-7587	Lead, Electrical, MCU Power	1
B1821BH050C125L	80204	5306-01-194-4974	Bolt, Machine, Hexagon Head	3
M13516/1-1	81349	5925-01-430-2318	Circuit Breaker, MCU Power	1
MS35489-114	96906	5325-00-174-9328	Grommet, Nonmetallic	1
MS27183-18	96906	5310-00-809-5998	Washer, Flat	3
MS 3367-2-0	96906	5975-00-899-4606	Strap, Tiedown, Electrical	16
MS35206-245	96906	5305-00-984-6193	Screw, Machine-Pan Head	2
MS35206-250	80205	5305-00-984-6198	Screw, Machine-Pan Head	2
MS35206-281	96906	5305-00-988-1725	Screw, Machine-Pan Head	2
MS35335-33	96906	5310-00-209-0786	Washer, Lock	2
MS35335-35	96906	5310-00-627-6128	Washer, Lock	1
MS35338-42	96906	5310-00-045-3299	Washer, Lock	4
MS51831-204	96906	5325-00-805-0339	Insert, Steel, Screw Thread Keylock	1

Table 2-2. Microclimate Cooling Unit Parts List.

Part No.	CAGE	NSN	Description	Qty
B43020-1	04577	8415-01-508-6626	Microclimate Cooling Unit	1
LSF00664	1K9E4	4720-01-522-2513	Umbilical, Coolant Hose Assembly	1
2-11-001-4	2S951	8415-01-522-2472	Vest, Cooling Garment, MCU – Sm	A/R
2-11-001-5	2S951	8415-01-522-2473	Vest, Cooling Garment, MCU – Med	A/R
2-11-001-6	2S951	8415-01-522-2477	Vest, Cooling Garment, MCU – Lg	A/R

SECTION II TOOLS REQUIRED

- a. Tool Kit, General Mechanics: Automotive, NSN 5180-00-177-7033.
- b. Shop Equipment, Automotive Maintenance and Repair: Field Maintenance, Basic, Less Power, NSN 4910-00-754-0705.
- c. Shop Equipment, Automotive Maintenance and Repair: Field Maintenance, Supplemental No.1, Less Power, NSN 4910-00-754-0706.
- d. Lifting device with weight capacity greater than 230 lb (104 kg) for removing MCS from equipped units.

SECTION III MODIFICATION PROCEDURES

NOTE

Pay attention to all Warnings per TM 5-2350-262-20-2, Section XIV, Group AV, Air Purifier Installation and to all Warnings, Cautions, and Notes per TM 5-2350-262-20-2, Section XXI, Group A6, Special Purpose Kits Installation, Microclimatic Cooling System (MCS) Tasks.

MCS preparation kits were installed on all M9 ACE vehicles per MWO 5-2350-262-50-1, dated 01 July 1996.

a. Vehicle Preparation:

1. Disconnect and cap the negative (ground) battery terminal per TM 5-2350-262-20-1, Battery Cable Replacement.
2. For vehicles equipped with MCS: Remove and discard all MCS equipment, cables, and hardware per TM 5-2350-262-20-2, Section XXI, Microclimatic Cooling System (MCS) Tasks (except for the two MCS power supply cable clamps on the mounting bracket on the left side of the driver's compartment wall that remain for reuse). Install the original NBC system equipment, electrical components, hoses, air purifier and heater and hardware per TM 5-235-262-20-2, Section XIV, Air Purifier Installation, and illustrations and parts list in TM 5-2350-262-24P.
3. Install set screws into the top fuel tank armor plate where the MCS mounting bolts were removed from, except for the three setscrews that will be removed and discarded in step b.1. below.
4. For vehicles not equipped with MCS and with the NBC system installed: Use the following procedure below beginning with paragraph b.1. MCU and Mounting Assembly Installation to install the CCS.

b. MCU and Mounting Assembly Installation:**NOTE**

Step 1 below applies to Figure 2-1.

1. Remove and discard three setscrews (2) from fuel tank armor plate (1) behind driver's compartment.

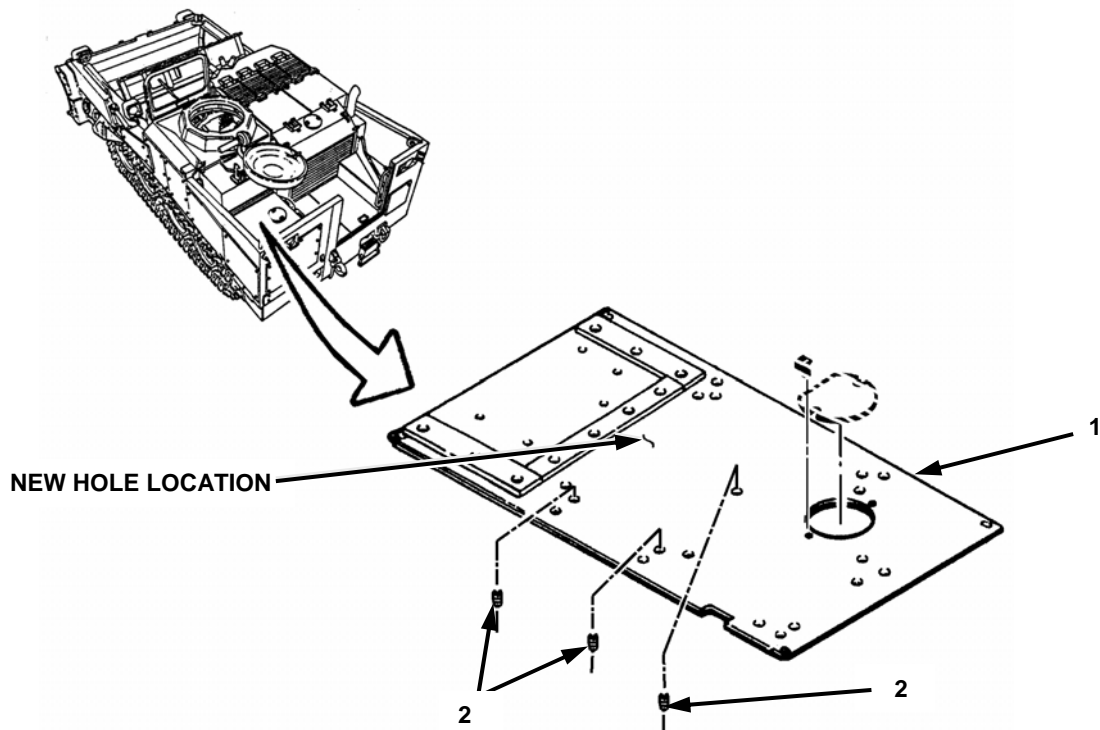

Figure 2-1. Fuel Tank Armor Plate.

NOTE

Steps 2 through 4 below apply to Figure 2-2.

2. Attach base bracket (12475721) (1) to fuel tank armor plate (2) with three flat washers (12387279-14) (3) and cap screws (B1821BH038F100N) (4) keeping end with shorter mounting rails (5) on base bracket (1) towards left side of vehicle.

WARNING

The fuel tank is located underneath the fuel tank armor plate. Follow the depth of drilling instructions described in steps b. 3. and b. 5. below (using a drill stop gauge set) to prevent drilling any deeper than 9/16 inch into the fuel tank armor plate to avoid any damage to the vehicle or serious injury to personnel.

CARC paint is extremely toxic. It can irritate skin and cause burns. Avoid inhaling. Use only with adequate ventilation. Avoid contact with skin, eyes, or clothing. In case of contact, immediately flush skin or eyes with water for at least 15 minutes. Get medical attention for eyes. Failure to comply may result in injury to personnel.

Serious hearing loss and eye injury can occur during drilling and grinding operations. Wear ear and eye protection. Failure to comply may result in injury to personnel.

3. Using a 7/16 inch diameter drill bit and a drill stop gauge set, drill a 7/16 diameter pilot hole 9/16 inch (14.29 mm) deep into the fuel tank armor plate (2) at location (6).
4. Remove three cap screws, flat washers, and base bracket. Retain cap screws, flat washers, and base bracket for later use.

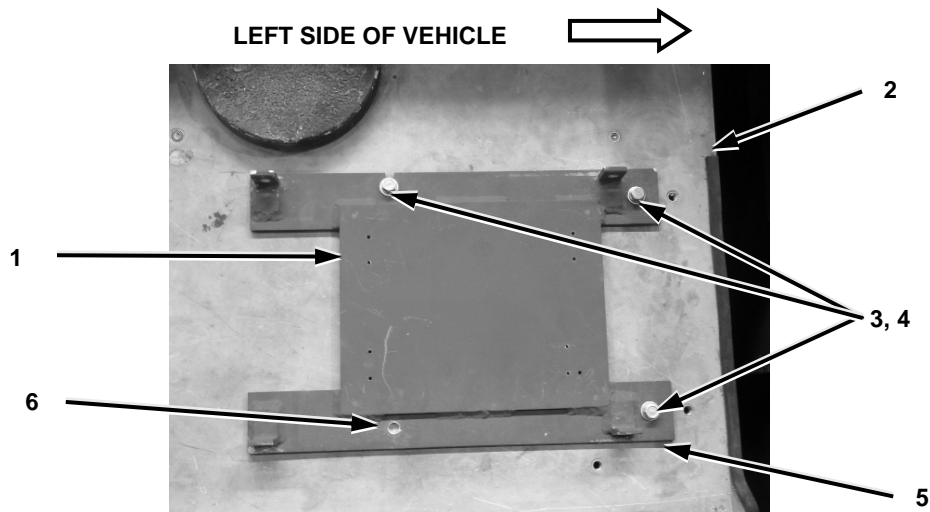

Figure 2-2. Locating and Drilling Fourth Hole for MCU Mounting Bracket Installation.

NOTE

Step 5 below applies to Figure 2-3.

5. Using a 1/2 inch diameter drill bit and a drill stop gauge set, drill a 1/2 inch (12.7 mm) hole, 1/2 inch (12.7 mm) deep into the fuel tank armor plate (1) at location (2) drilled in step b.3. above. Tap hole (2) using a bottom end tap set to 9/16-12 UNC-2-A. Install steel insert (MS51831-204) into threaded hole (2).

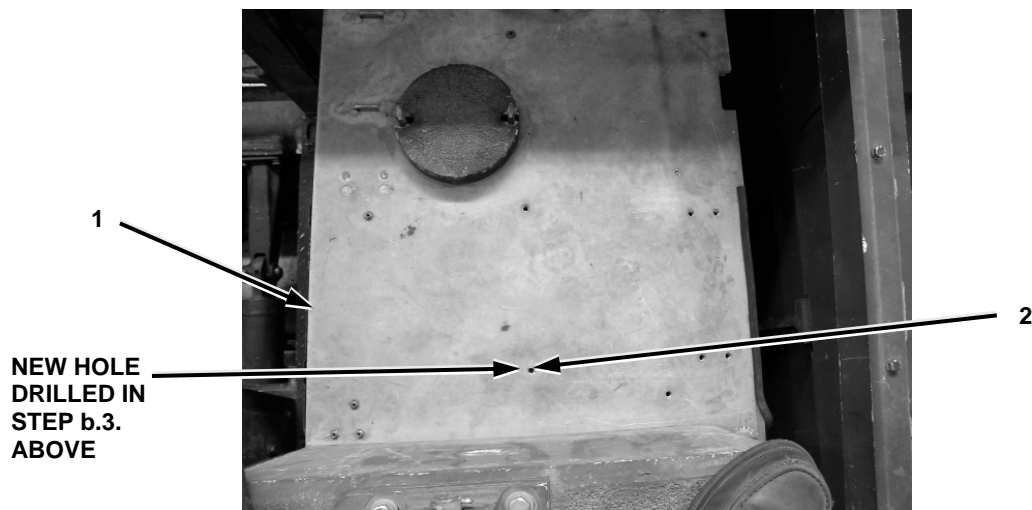

Figure 2-3. Drilling, Tapping and Installing Steel Insert in Fourth Mounting Hole.

NOTE

Steps 6 through 8 below apply to Figure 2-4.

6. Attach four shock mounts (ME100-4-T) (6) to base bracket (12475721) (7) with eight lock washers (12387272-41) (1), pan head machine screws (12387301-230) (2) and nuts (12387277-262) (5). Hand-tighten pan head screws until they are snug only.
7. Insert threaded end of four cap screws (B181BH025C700N) (3) up through bottom of support bracket (12475722) (4) with screw heads facing downward toward base bracket (7).
8. Attach support bracket (4) to shock mounts (6) with four lock washers (12387272-42) (8) and pan head machine screws (12387301-246) (9) keeping notch cutout (10) on support bracket (4) towards the end on base bracket (7) with shorter mounting rails. Hand-tighten pan head screws until they are snug only.

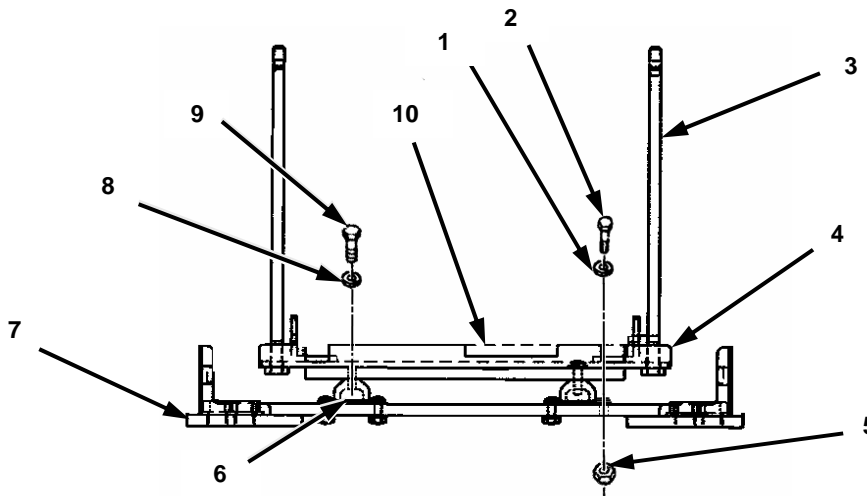

Figure 2-4. Assembly of MCU Base and Support Bracket.

NOTE

Steps 9 through 11 below apply to Figure 2-5.

9. Install the assembled base and support brackets (4) on fuel tank armor plate with the three flat washers and cap screws retained from step b.4. above and with one additional flat washer (12387279-14) (5), lock washer (MS35338-103) (6), and cap screw (B1821BH038F100N) (7). Ensure the end of the assembled base bracket with the shorter mounting rails and the support bracket end with the notch cutout are both facing the left side of vehicle.
10. Place MCU (B43020-1) (8) on assembled base and support bracket (4) with the electrical and coolant umbilical connectors on the rear of the MCU facing the left side of the vehicle.
11. Install top bracket (12475723) (3) on top of the MCU (8) with four self-locking wing nuts (10917219) (1) on cap screws (2). Hand-tighten wing nuts until they are snug only.

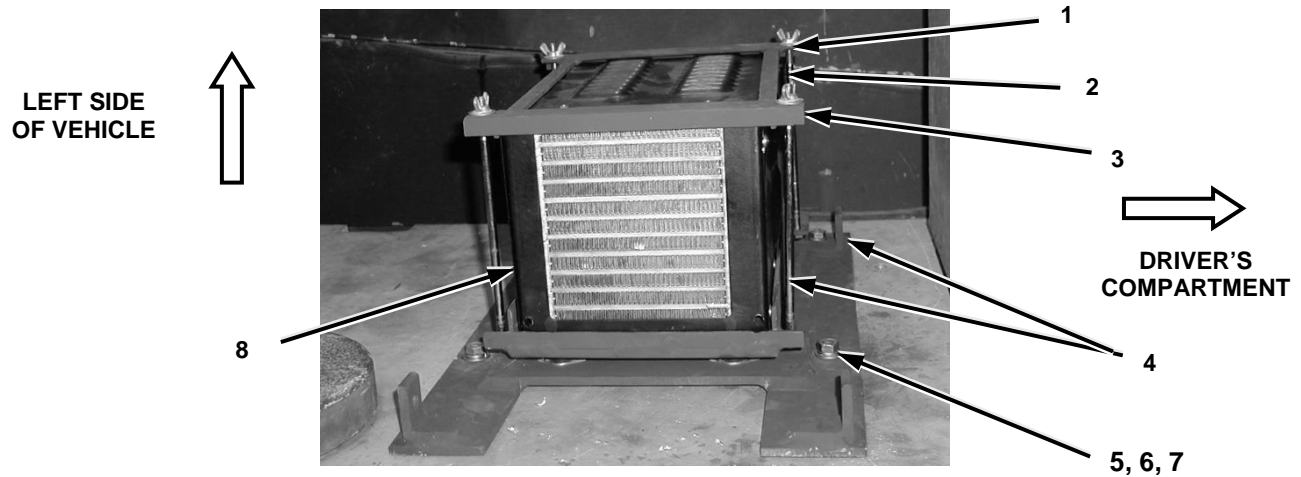

Figure 2-5. MCU Installation on Base and Support Bracket Assembly.

c. **Assembly and Installation of MCU Wiring Harness, Grommet and Grommet Plate and Coolant Umbilical and Umbilical Bypass Control Assembly (BCA):**

CAUTION

Avoid crimping coolant umbilical.

NOTE

Steps 1 through 3 below apply to Figure 2-6.

1. Position the MCU wiring harness (12491610) (2) against the outside of the MCU coolant umbilical (LSF00664) (1) as shown in Figure 2-6 below.
2. Slide the grommet plate (12475741) (4) and grommet (MS35489-114) (3) over MCU end of coolant umbilical (1) and positive electrical lead of MCU wiring harness (2). Slide grommet (3) and grommet plate (4) towards the Bypass Control Assembly (BCA) (5) end of the coolant umbilical.
3. Insert grommet (3) into the grommet plate (4).

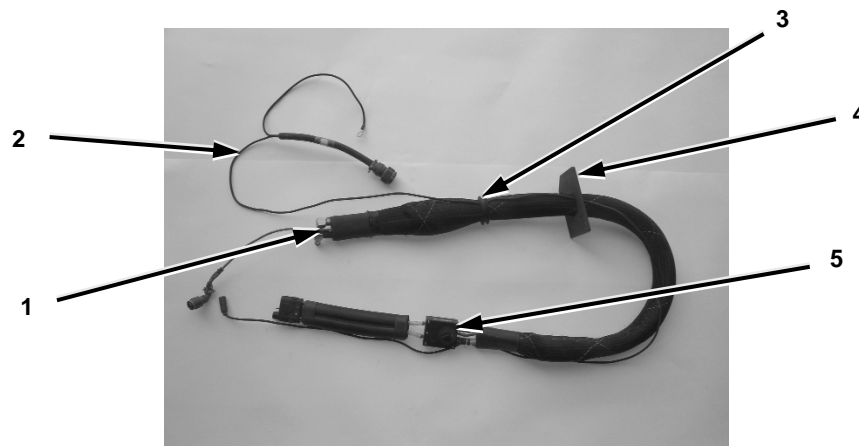

Figure 2-6. Assembly of MCU Wiring Harness, Grommet and Grommet Bracket on MCU Umbilical.

NOTE

Step 4 below applies to Figure 2-7.

4. For vehicles equipped with MCS preparation kit only, remove screw (1), washer (2), and MCS prep spacer plate (4) from the upper left rear corner of driver's compartment and the angle plate (3) from the left front side of the radio box case. Discard MCS prep spacer plate, angle plate, and attaching hardware.

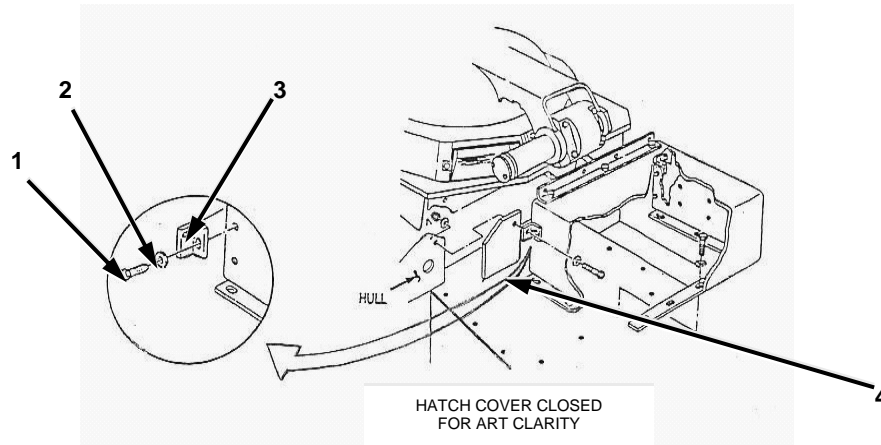

Figure 2-7. Removal of MCS Preparation Kit Brackets.

CAUTION

Avoid crimping coolant umbilical.

NOTE

Steps 5 and 6 below apply to Figure 2-8.

5. Slide the assembled coolant umbilical (2), MCU end first, through the MCS preparation hole (1) at the upper left rear corner of the driver's compartment and toward the rear of vehicle with the MCU wiring harness (3) and assembled grommet (4) and grommet plate (5).
6. Fasten the grommet plate (5) (with the angled corner in the upper left rear corner of compartment) to the rear wall of the driver's compartment (6) using two lock washers (MS35335-33) (7) and pan head machine screws (MS35206-281) (8).

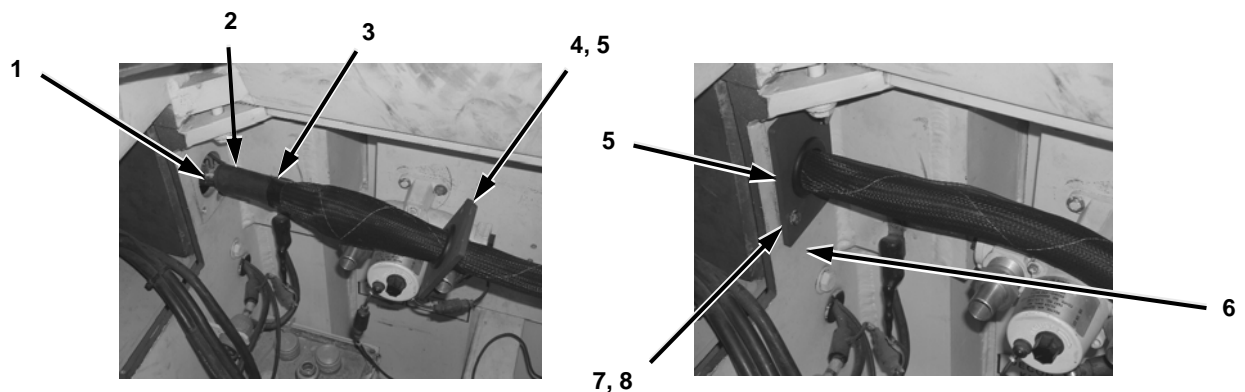

Figure 2-8. Installation of MCU Umbilical and Grommet Plate at Left Rear of Driver's Compartment.

CAUTION

Avoid crimping coolant umbilical.

NOTE

Steps 7 through 9 below apply to Figure 2-9.

7. Remove the NBC assembly (6) from driver's compartment sidewall bracket (2) by removing four machine bolts (4) and flat washers (5). Retain NBC assembly, machine bolts and flat washers for later use.
8. Install the umbilical BCA (1) to the top of the BCA bracket (12475751) (3) with two lock washers (MS35338-42) (7) and pan head machine screws (MS35206-245) (8).
9. Install the umbilical BCA bracket (3) behind the NBC assembly (6) to the driver's compartment sidewall bracket (2) with four machine bolts (4) and flat washers (5) retained in step c.7 above.

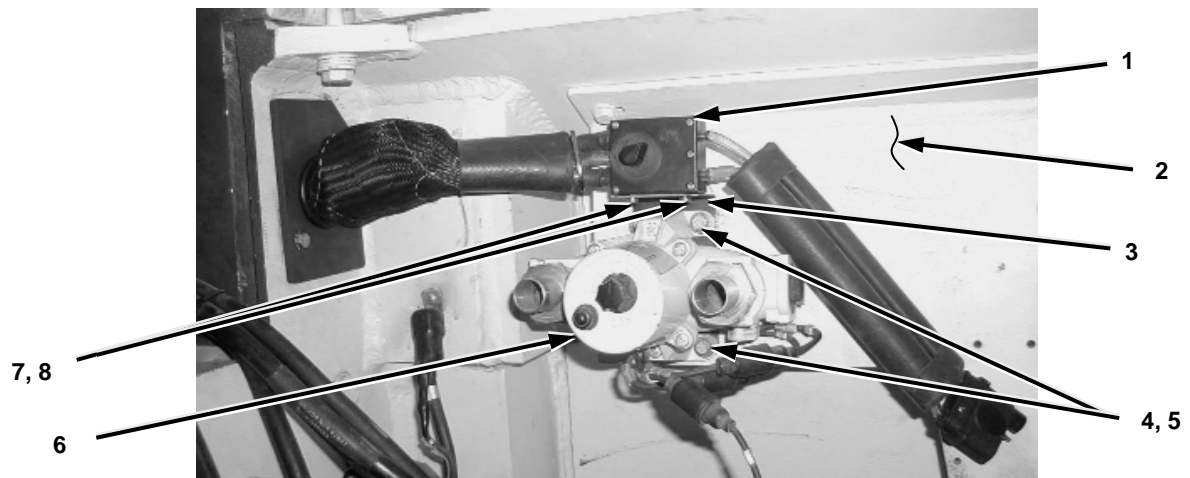

Figure 2-9. MCU Coolant Umbilical BCA Installation.

d. Circuit Breaker Installation in Driver's Compartment:

NOTE

Steps 1 and 2 below apply to Figure 2-10.

1. Remove two machine bolts (3) and bracket assembly (2) from sidewall. Retain machine bolts and bracket assembly for later use.
2. Remove two machine screws (1), lock washers (5), nuts (6) and circuit breaker (4) from bracket assembly (2). Discard machine screws and lock washers. Retain nuts and circuit breaker for later use.

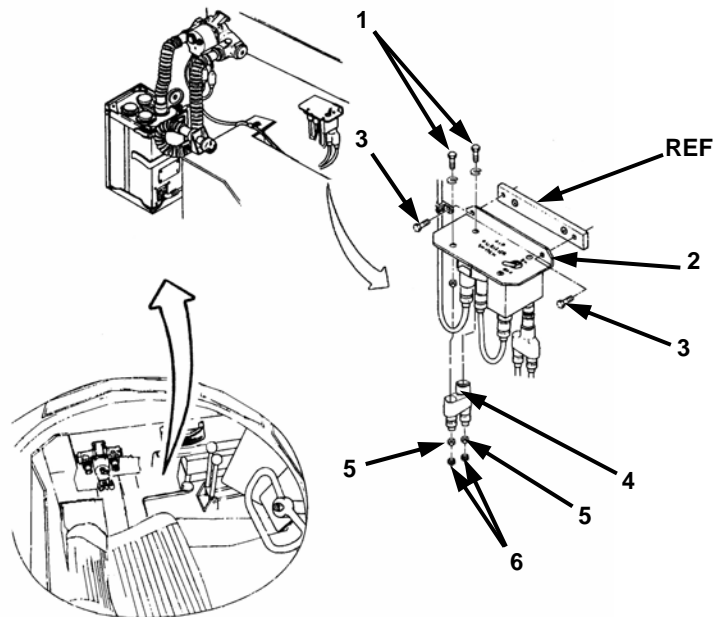

Figure 2-10. Preparation for CCS Circuit Breaker Installation.

NOTE

Steps 3 and 4 below apply to Figure 2-11.

3. Install circuit breaker (M13516/1-1) (1) on top surface of existing bracket assembly (3) with circuit breaker (7), retained from step d.2. above, in its original position using two lock washers (MS35338-42) (4) and longer pan head machine screws (MS35206-250) (5) with the nuts (6) retained from step d.2. above.
4. Reinstall bracket assembly (3) on sidewall with the two machine bolts (2) retained from step d.1. above.

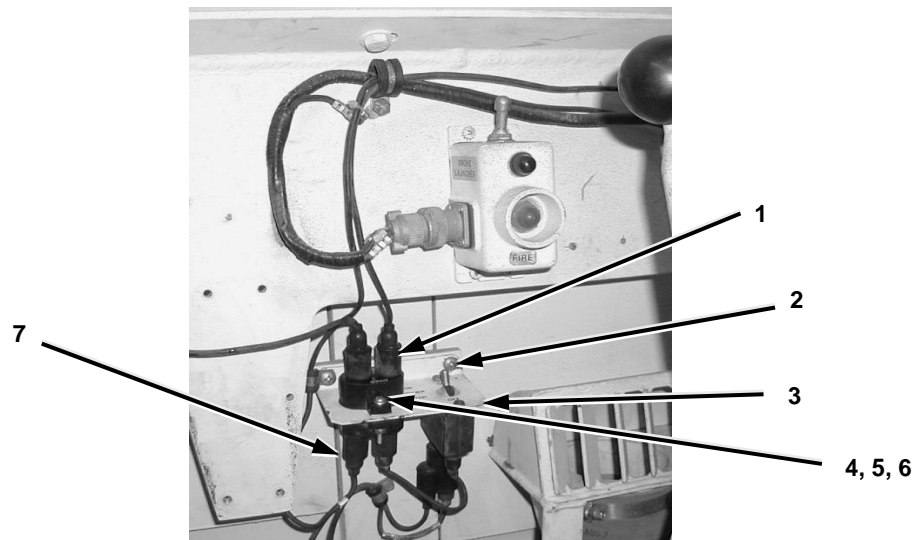

Figure 2-11. CCS Circuit Breaker Installation.

e. CCS Power Lead and MCU Power Lead Installation and CCS Power Lead Routing:

NOTE

Steps 1 and 2 below apply to Figure 2-12.

1. Connect positive lead (2) of MCU wiring harness (12491610) to left side of circuit breaker (4).
2. Connect MCU Power Lead (12491611-2) (3) to right side of circuit breaker (4). Route the opposite end of the MCU Power Lead (3) up through the wire loop clamp (1) and toward the left front of the driver's compartment through the second wire loop clamp on the upper left sidewall of the driver's compartment.

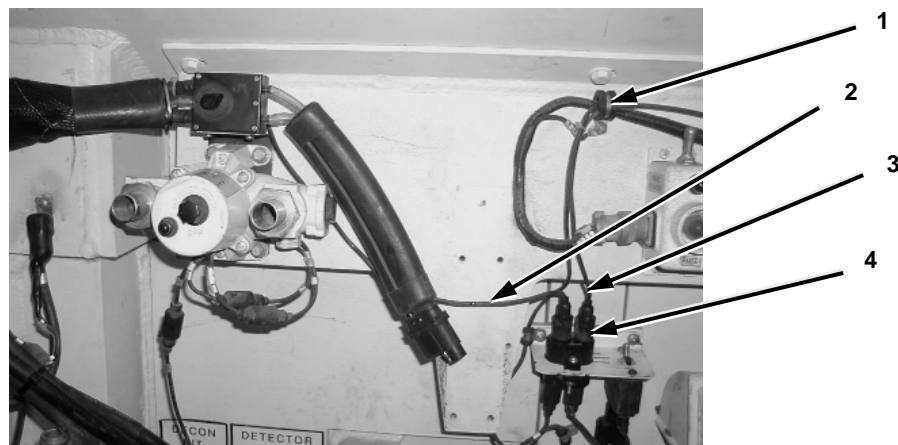

Figure 2-12. MCU Power Lead and CCS Power Lead Connections to Circuit Breaker.

NOTE

Step 3 below applies to Figure 2-13.

3. Continue routing the MCU Power Lead (12491611-2) (2) forward, behind the instrument panels and out the lower front hole (1) of the driver's compartment.

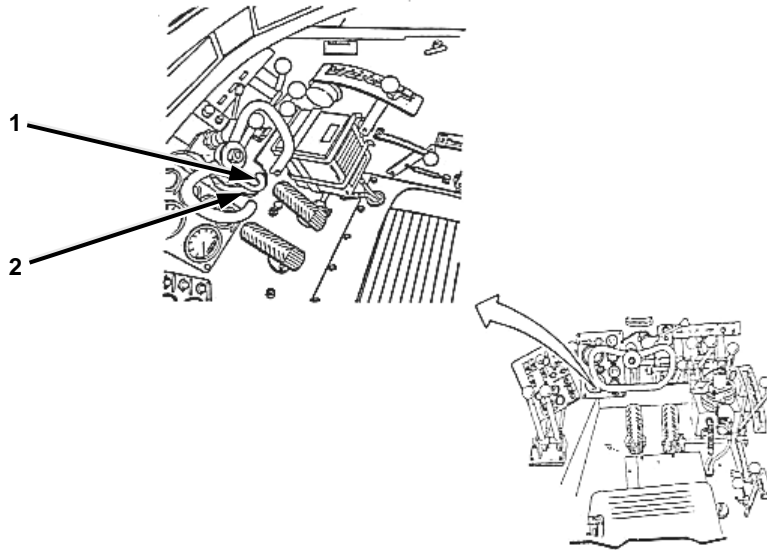

Figure 2-13. MCU Power

Breaker to Lower Front of Driver's Compartment.

Lead Routing from Circuit

NOTE

Step 4 below applies to Figure 2-14.

4. Route the MCU Power Lead (12491611-2) (2) along the existing wire harness (3). Use 5 or 6 Electrical Tie Straps (MS 3367-2-0) (4) to connect the MCU Power Lead (12491611-2) (2) to the existing Wiring Harness (3) on the front and right outside of the driver's compartment. Connect the MCU Power Lead (12491611-2) (2) end to the end of the MCU Power Lead (12491611-1) (1) on the right outside of the driver's compartment inside the engine compartment.

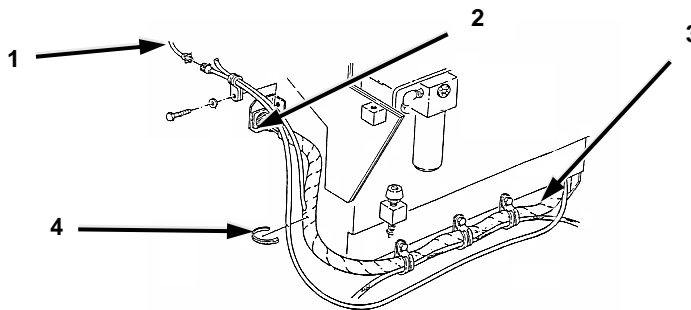

Figure 2-14. MCU Power Lead Routing from Driver's Compartment to Engine Terminal.

NOTE

Step 5 below applies to Figure 2-15.

5. Route and connect the opposite end of the MCU Power Lead (12491611-1) (2) to the power terminal (3) on the top of the engine behind the alternator. Use 5 or 6 Electrical Tie Straps (MS 3367-2-0) (1) to fasten the MCU Power Lead (1) to the right outside of the driver's compartment where required.

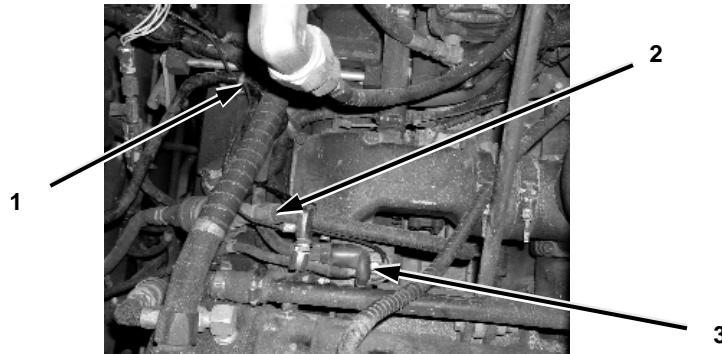

Figure 2-15. MCU Power Lead Connection at Engine Terminal.

f. Connecting the Coolant Umbilical assembly and Electrical Leads to the MCU:

NOTE

Steps 1 and 2 below apply to Figure 2-16.

1. Adjust coolant umbilical (1) and MCU wiring harness power lead (2) so excess umbilical and power lead are outside and behind the left rear of the driver's compartment.
2. Secure the positive electrical lead (3) to the outside of the coolant umbilical (1) with 3 or 4 tie-straps (MS 3367-2-0) (2).

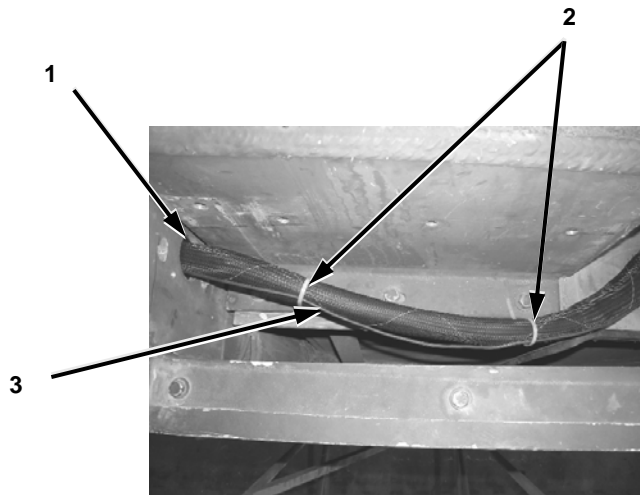

Figure 2-16. Securing Positive Lead to Outside of Coolant Umbilical.

NOTE

If coolant umbilical lines are not connected to MCU correctly, cooling vest will not operate properly.

Steps 3 through 5 below apply to Figure 2-17.

3. Attach coolant umbilical hose connectors (7) and (8) to SUPPLY (3) and RETURN (5) ports on rear of MCU (4) ensuring supply and return hoses are connected to the supply and return ports on the rear of the MCU as marked.
4. Attach the coolant umbilical BCA lead (6), bundled with the coolant umbilical, to the CONTROL connector (2) on the rear of the MCU (4).
5. Attach the wiring harness connector (9) to the upper right connector (1) on the rear of the MCU (4).

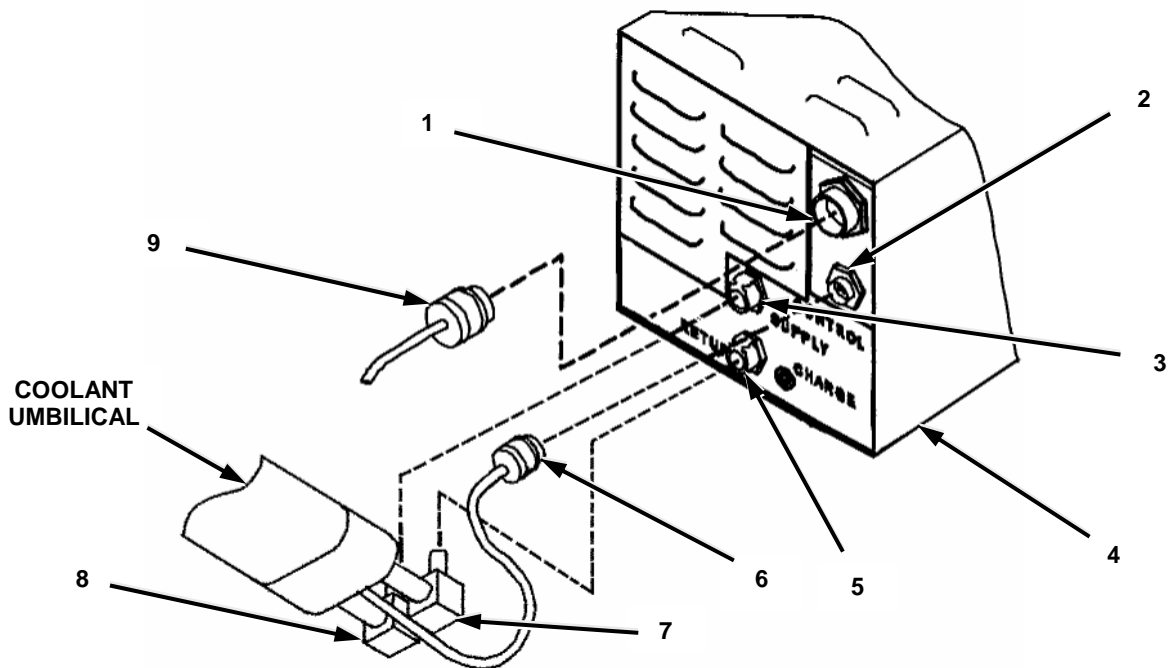

Figure 2-17. Coolant Umbilical and Electrical Connections to MCU.

WARNING

CARC paint is extremely toxic. It can irritate skin and cause burns. Avoid inhaling. Use only with adequate ventilation. Avoid contact with skin, eyes, or clothing. In case of contact, immediately flush skin or eyes with water for at least 15 minutes. Get medical attention for eyes. Failure to comply may result in injury to personnel.

NOTE

Steps 6 through 8 below apply to Figure 2-18.

6. Remove cap screw (1) and flat washer (3) from the MCU base plate (4). Retain cap screw and flat washer for later use.
7. Clean painted surface around hole (5) in MCU base plate (4).
8. Install the ground wire (6) from the MCU wiring harness to the MCU base plate (4) using the cap screw (1) and flat washer (3) from step f.6. above and with star washer (MS35335-35) (2), ensuring the attaching surface on the MCU base plate is bare and unpainted.

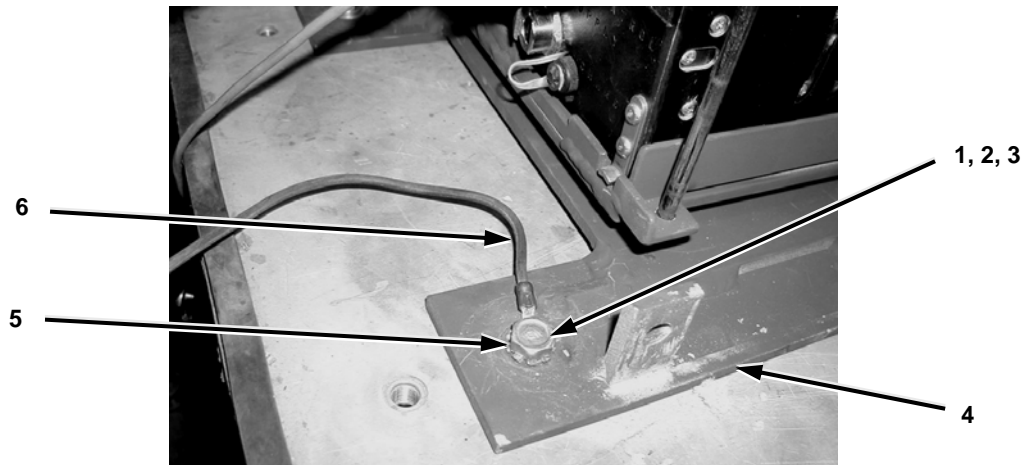

Figure 2-18. Installing MCU Ground Wire Connection.

NOTE

Step 9 below applies to Figure 2-19.

9. Install the access cover (12475724) (1) on the MCU base bracket (6) with the angled and open end facing the left side of the vehicle using four cap screws (B1821BH038C150N) (2), hex nuts (12387305-9) (3) and lock washers (12387272-46) (4) and eight flat washers (12387279-14) (5).

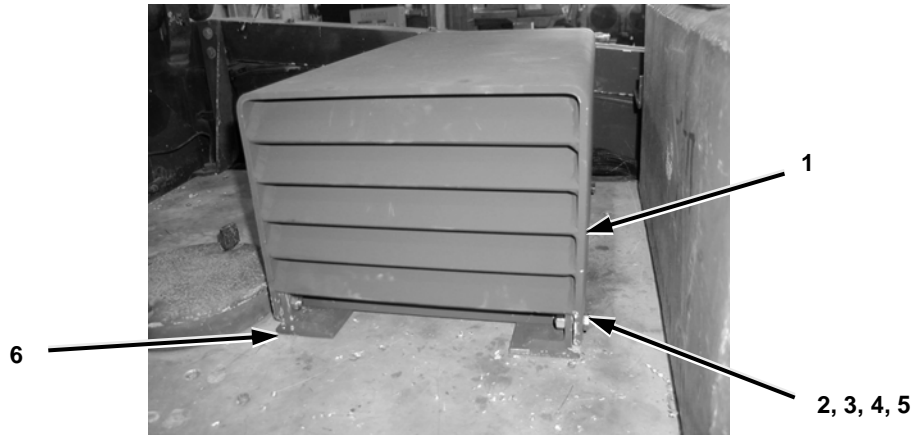

Figure 2-19. MCU Access Cover Installation.

NOTE

Step 10 below applies to Figure 2-20.

10. Install the coolant umbilical guard (12475737) (4) to the left outside of the radio equipment case (1) behind the driver's compartment with three flat washers (MS27183-18) (2) and machine bolts (B1821BH050C125L) (3).



Figure 2-20. Coolant Umbilical Guard Installation.

11. Re-connect the negative battery ground cable per TM 5-2350-262-20-1.

SECTION IV – SYSTEM CHARGING & PURGING PROCEDURES

NOTE

Use Charge/Purge Kit – MCU Cooling (4700) for procedures in this section.
Step 1 and 2 below apply to Figure 2-21.

a. Mixing Coolant:

1. Pour tap water to “30% concentration fill line” on bottle (4700) (2) and add propylene glycol (MIL-P-83800) (1) to “fill propylene glycol to here” line on bottle (2).

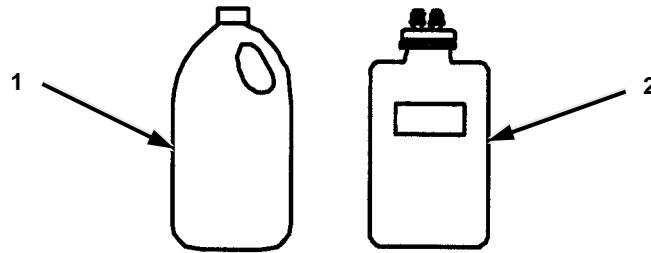

Figure 2-21. Mixing Coolant Components.

2. Cap bottle (2) and shake well to mix.

b. Charging Microclimate Cooling Garment (MCG):

NOTE

Step 1 below applies to Figure 2-22.

1. Connect latch tether (2) to MCG (2-11-001-4, 2-11-001-5, or 2-11-001-6) (1).

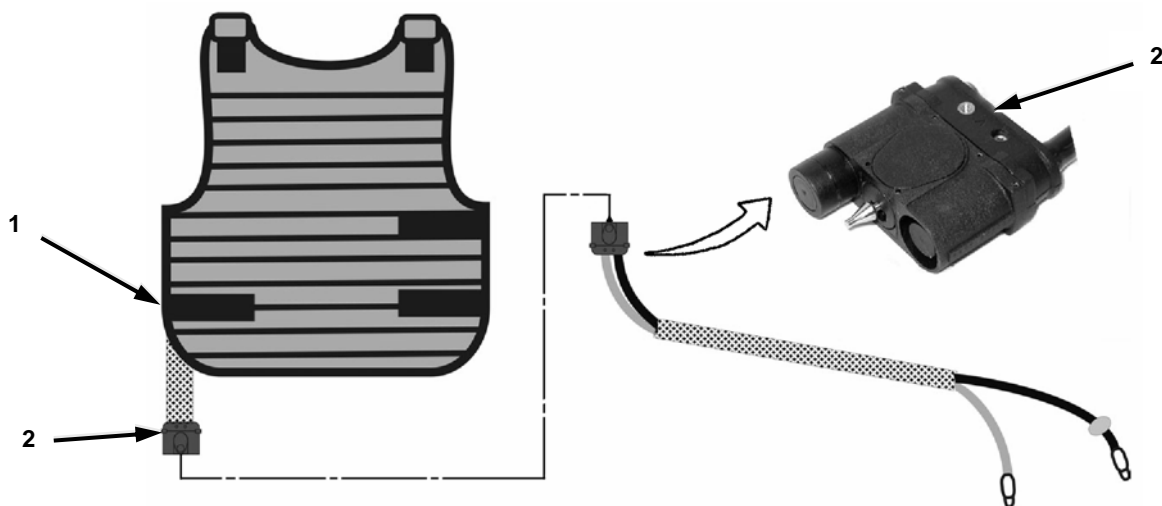

Figure 2-22. Latch Tether for Charging MCG.

NOTE

Steps 2 through 5 below apply to Figure 2-23.

2. Fill bottle (7) with solution from Section IV, step a.

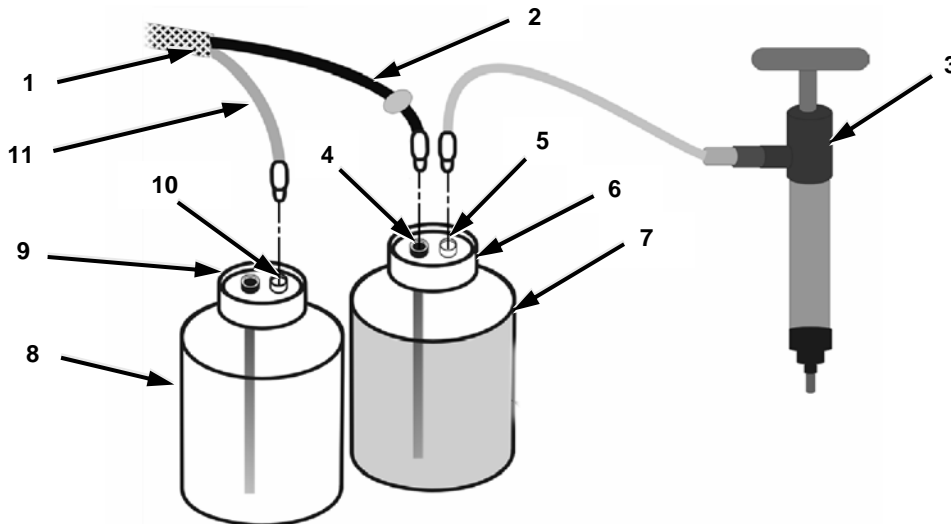

Figure 2-23. Charge/Purge Kit for Charging MCG.

3. Connect black tube (2) on latch tether (1) to black connector (4) on lid (6) of FILLED bottle (7).
4. Connect clear tube (11) on latch tether (1) to white connector (10) on lid (9) of EMPTY bottle (8).
5. Connect pump (3) to white connector (5) on lid (6) of FILLED bottle (7).

NOTE

Steps 6 through 9 below apply to Figure 2-24.
Solution will begin to flow into EMPTY bottle, indicating that MCG is flooded.

6. Operate hand pump (5) to fill MCG (1).

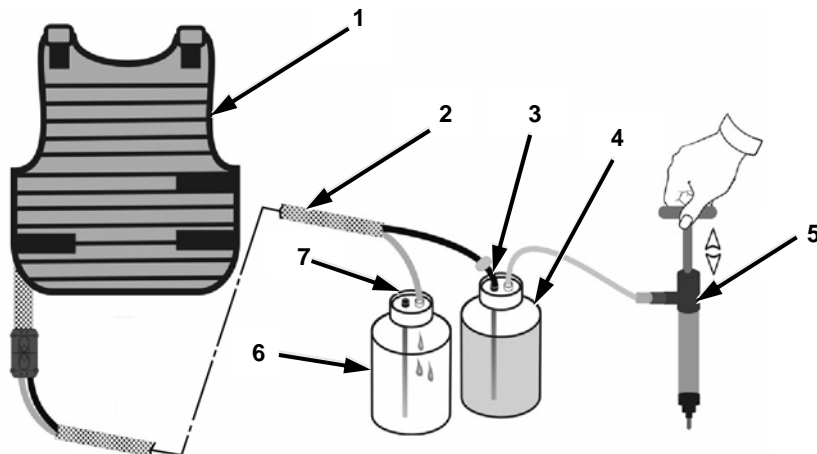

Figure 2-24. Charging MCG.

7. Disconnect MCG (1) from latch tether (2).
8. Release pressure from bottles (4 and 6) by untightening lids (3 and 7).
9. Transfer any solution from EMPTY bottle (6) back into FILLED bottle (4).

c. Purging MCG:

NOTE

Steps 2 through 3 below apply to Figure 2-25.

1. Connect black tube (2) on latch tether (1) to black connector (2) on lid (6) of EMPTY bottle (7).

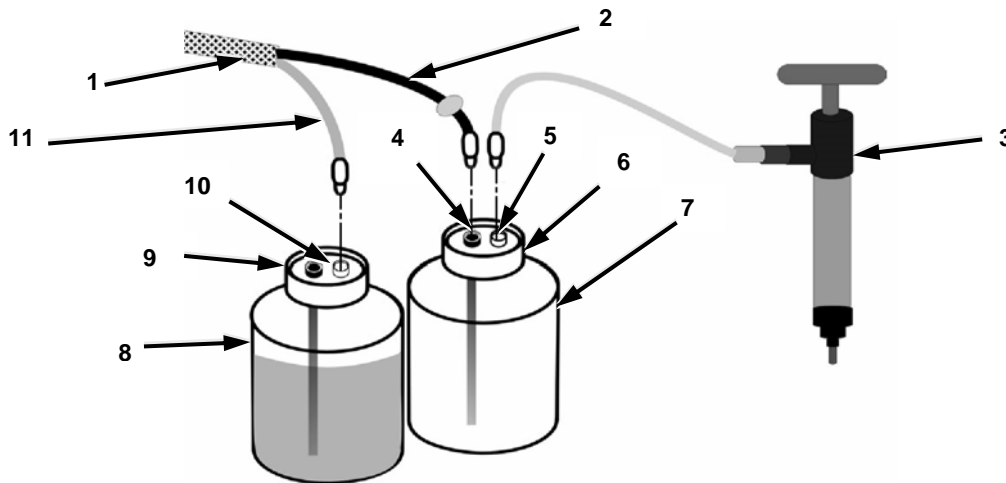

Figure 2-25. Charge/Purge Kit for Purging MCG.

2. Connect clear tube (11) on latch tether (1) to white connector (10) on lid (9) of FILLED bottle (8).
3. Connect pump (3) to white connector (5) on lid (6) of EMPTY bottle (7).

NOTE

Step 4 below applies to Figure 2-26.

4. Connect latch tether (2) to MCG (1).

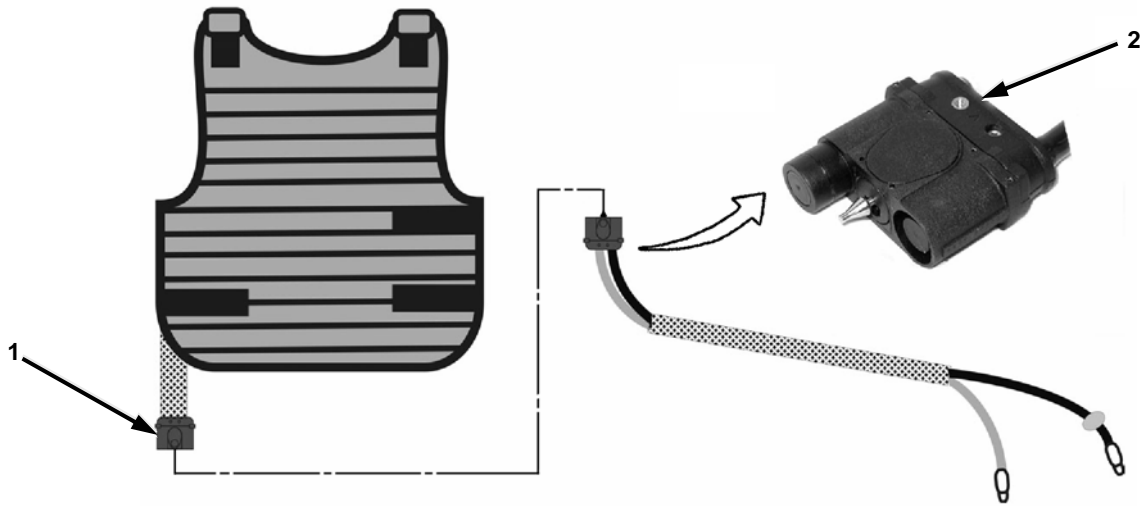

Figure 2-26. Latch Tether for Purging MCG.

NOTE

Steps 5 through 7 below apply to Figure 2-27.

5. Loosen cap (6) on FILLED bottle (5) to allow for purging.

NOTE

Solution will flow out into FILLED bottle. When flow stops, purging is complete.

6. Operate hand pump (4) to purge MCG (1).

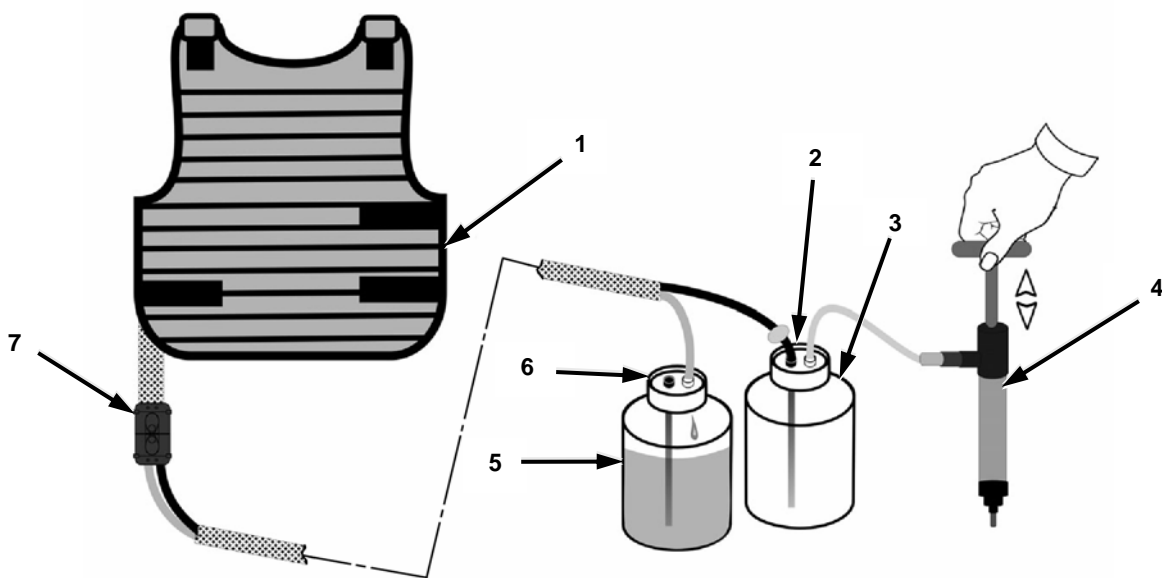

Figure 2-27. Purging MCG.

7. Disconnect MCG (1) from latch tether (2).

d. Charging Microclimate Cooling Unit (MCU):

NOTE

Step 1 below applies to Figure 2-28.

1. Connect release tether (2) to MCU (1).

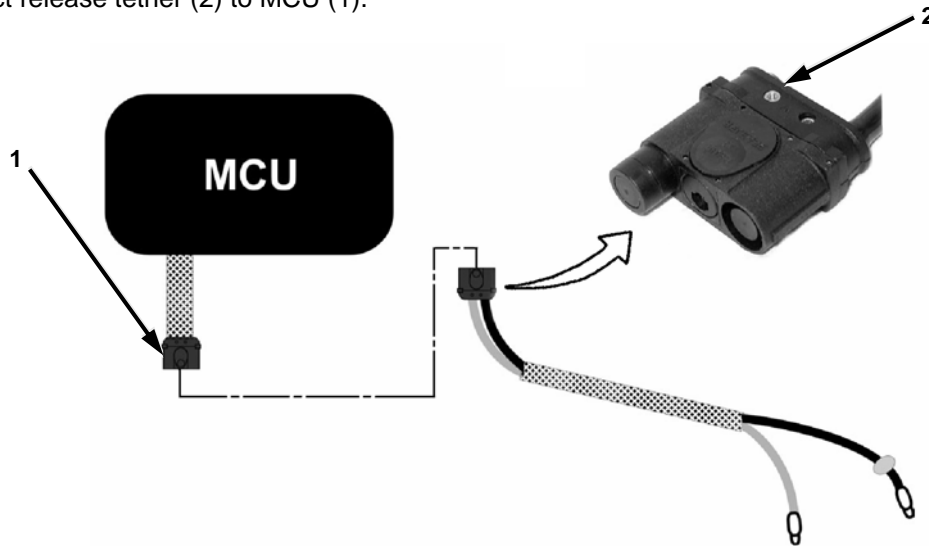

Figure 2-28. Release Tether for Charging MCU.

NOTE

Steps 2 through 5 below apply to Figure 2-29.

2. Fill one bottle (7) with solution from Section IV, step a.

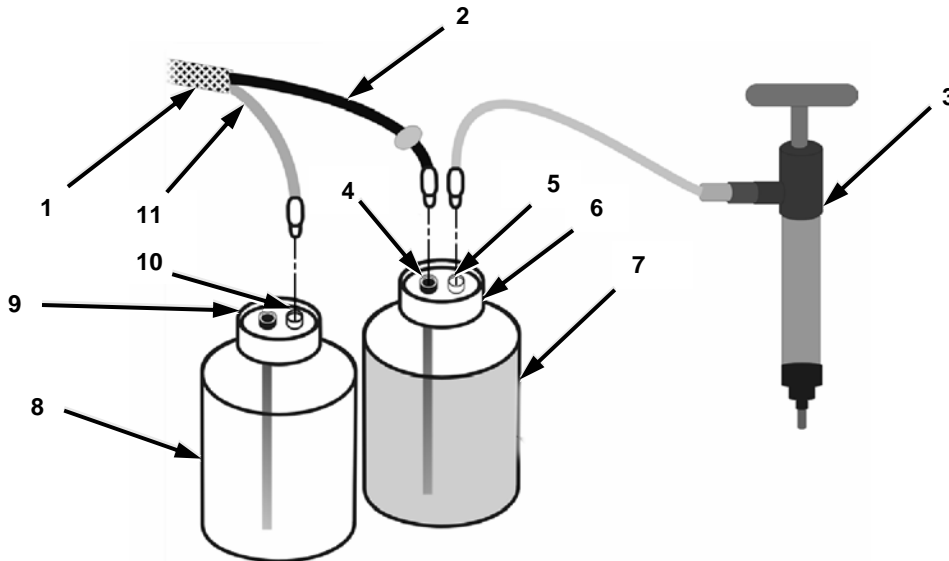

Figure 2-29. Charge/Purge Kit for MCU.

3. Connect black tube (2) on release tether (1) to black connector (4) on lid (6) of FILLED bottle (7).
4. Connect clear tube (11) on release tether (1) to white connector (10) on lid (9) of EMPTY bottle (8).
5. Connect pump (3) to white connector (5) on lid (6) of FILLED bottle (7).

NOTE

Steps 6 through 9 below apply to Figure 2-30.
Solution will begin to flow into EMPTY bottle to indicate that MCU is flooded.

6. Operate hand pump (5) to fill MCU (1).

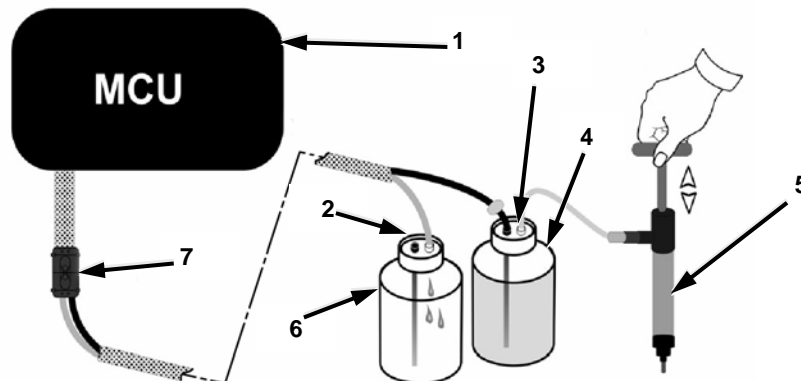

Figure 2-30. Charging MCU.

7. Disconnect MCU (1) from release tether (2).

8. Release pressure from bottles (4 and 6) by untightening lids (3 and 7).
9. Transfer any solution from EMPTY bottle (6) back into FILLED bottle (4).

e. Purging MCU:

CAUTION

Do not use compressed air to purge MCU or coolant umbilical. High pressure will damage seals.

NOTE

Steps 1 through 6 below apply to Figure 2-31.

1. Connect black tube (2) on release tether (1) to black connector (4) on lid (6) of EMPTY bottle (7).
2. Connect clear tube (11) on release tether (1) to white connector (10) on lid of FILLED bottle (8).
3. Connect pump (3) to white connector (5) on lid (6) of EMPTY bottle (7).

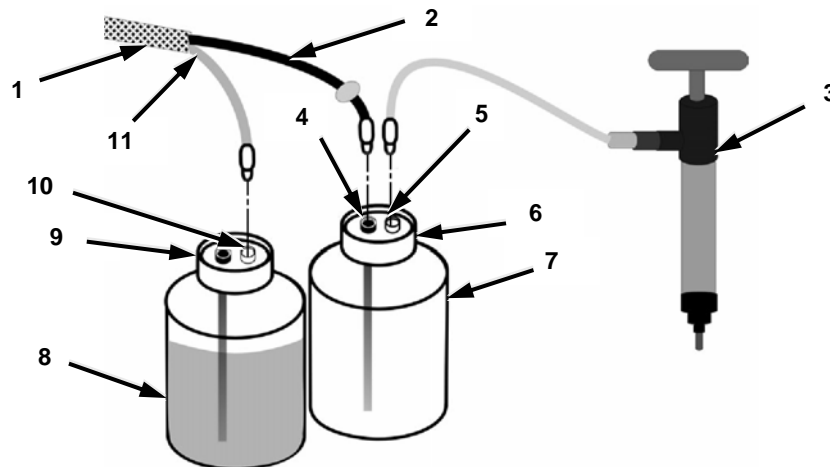

Figure 2-31. Charge/Purge Kit for Purging MCU.

NOTE

Step 4 below applies to Figure 2-32.

4. Connect release tether (2) to MCU (1).

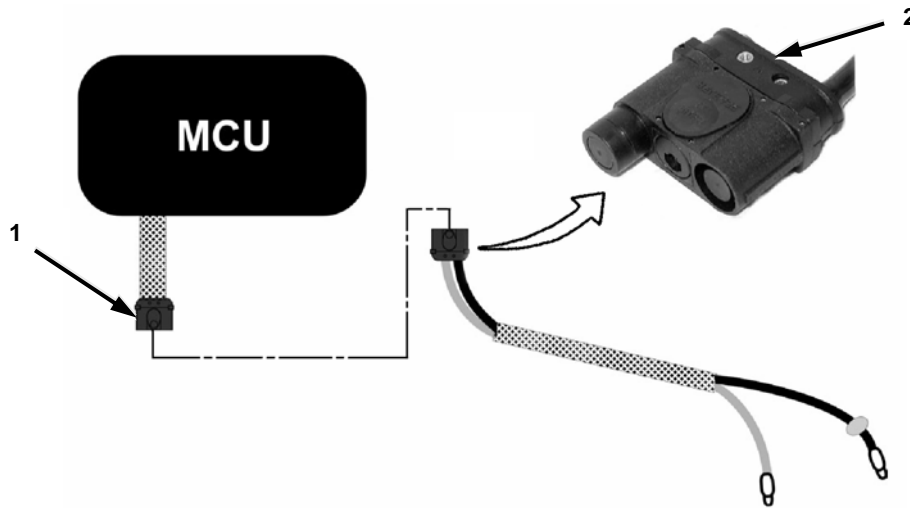

Figure 2-32. Release Tether for Purging MCU.

NOTE

Steps 5 and 7 below apply to Figure 2-33.
Solution will flow out into FILLED bottle. When flow stops, purging is complete.

5. Loosen cap (3) on FILLED bottle (4) to allow for purging.
6. Operate hand pump (5) to purge MCU (1).

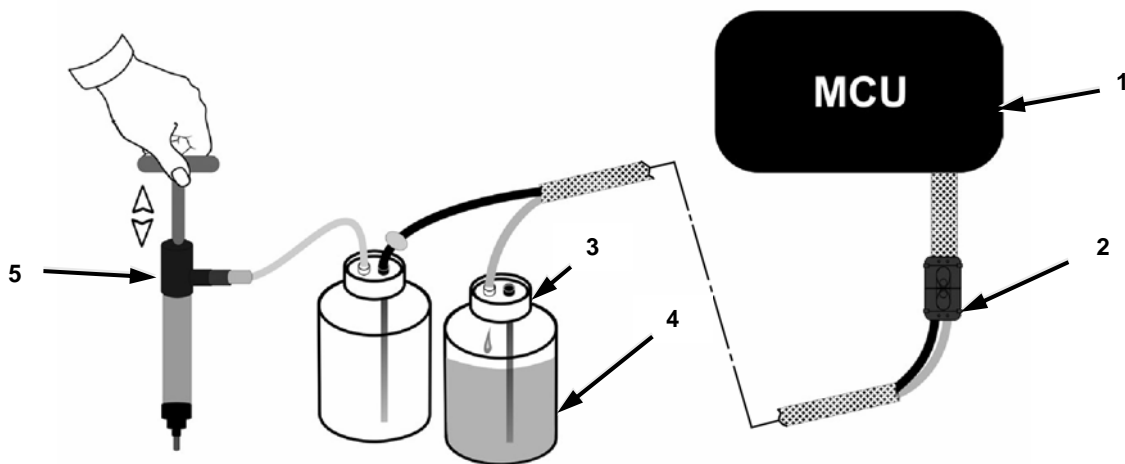

Figure 2-33. Purging MCU and Hand Pump.

7. Disconnect MCU (1) from release tether (2).

CHAPTER 3 CREW COOLING SYSTEM INSTALLATION FOR FORCE XXI BATTLE COMMAND—BRIGADE AND BELOW (FBCB2) EQUIPPED VEHICLES ONLY

SUBJECT: Installation of new configuration Crew Cooling System (CCS) for vehicles equipped with FBCB2 systems only.

DATE: 3 JANUARY 2006.

DESCRIPTION: For vehicles with FBCB2 systems installed, the NBC system equipment and the left seatbelt will be installed in different positions than vehicles without FBCB2 systems.

TM REFERENCES: The technical manual references in this procedure are: TM 5-2350-262-20-1 and 2, dated January 1997 and TM 5-2350-262-24P, dated March 2000.

SECTION I - TOOLS REQUIRED

- a. Tool Kit, General Mechanics: Automotive, NSN 5180-00-177-7033.
- b. Shop Equipment, Automotive Maintenance and Repair: Field Maintenance, Basic, Less Power, NSN 4910-00-754-0705.
- c. Shop Equipment, Automotive Maintenance and Repair: Field Maintenance, Supplemental No.1, Less Power, NSN 4910-00-754-0706.
- d. Lifting device with weight capacity greater than 230 lb (104 kg) for removing driver's seat from vehicle.

SECTION II - MODIFICATION PROCEDURES

NOTE

Pay attention to all Warnings per TM 5-2350-262-20-2, Section XIV, Group AV, Air Purifier Installation and to all Warnings, Cautions, and Notes per TM 5-2350-262-20-2, Section XXI, Group A6, Special Purpose Kits Installation, Microclimatic Cooling System (MCS) Tasks.

MCS preparation kits were installed on all M9 ACE vehicles per MWO 5-2350-262-50-1, dated 01 July 1996.

- a. Vehicle Preparation:
 1. Disconnect and cap the negative (ground) battery terminal per TM 5-2350-262-20-1, Battery Cable Replacement.
 2. For vehicles equipped with MCS: Remove and discard all MCS equipment, cables, and hardware per TM 5-2350-262-20-2, Section XXI, Microclimatic Cooling System (MCS) Tasks (except for the two MCS power supply cable clamps on the mounting bracket on the left side of the driver's compartment wall that remain for reuse.
 3. Install set screws into the top fuel tank armor plate where the MCS mounting bolts were removed from, except for the three setscrews that will be removed and discarded in step b.1. below.
 4. Remove driver's seat per TM 5-2350-262-20-2, Seat Assembly Replacement and Repair.
 5. Remove driver's left seatbelt from hull per TM 5-2350-262-20-2, Seatbelt Assembly Replacement.

WARNING

CARC paint is extremely toxic. It can irritate skin and cause burns. Avoid inhaling. Use only with adequate ventilation. Avoid contact with skin, eyes, or clothing. In case of contact, immediately flush skin or eyes with water for at least 15 minutes. Get medical attention for eyes. Failure to comply may result in injury to personnel.

Serious hearing loss and eye injury can occur during drilling and grinding operations. Wear ear and eye protection. Failure to comply may result in injury to personnel.

NOTE

Steps 6 through 9 below apply to Figure 3-1.

6. Use suitable cutting device to cut left seatbelt bracket (2) at a distance 0.5 inches (12.7 mm) from center of existing left seatbelt bolt hole.

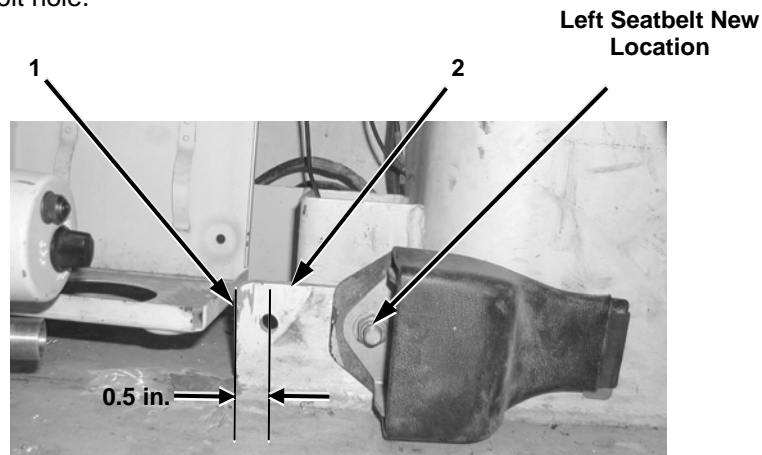

Figure 3-1. Left Seatbelt Bracket.

WARNING

CARC paint is extremely toxic. It can irritate skin and cause burns. Avoid inhaling. Use only with adequate ventilation. Avoid contact with skin, eyes, or clothing. In case of contact, immediately flush skin or eyes with water for at least 15 minutes. Get medical attention for eyes. Failure to comply may result in injury to personnel.

Serious hearing loss and eye injury can occur during drilling and grinding operations. Wear ear and eye protection. Failure to comply may result in injury to personnel.

7. Use suitable grinding device and smooth edge (1) cut in step 6 above.
8. Measure distance from compartment floor to center of existing left seatbelt bolt hole. Mark new hole 2.5 inches (63.5 mm) towards vehicle front from existing hole and height measurement previously recorded.
9. Using ½ inch diameter drill bit, drill a 1/2 inch (12.7 mm) through hole in left seatbelt bracket (2).

NOTE

Step 10 below applies to Figure 3-2.

10. Using 7/32 inch diameter drill bit, drill eight 7/32 inch (5.556 mm) holes and tap ¼ inch x 20 in driver's compartment back wall and next to left side wall.

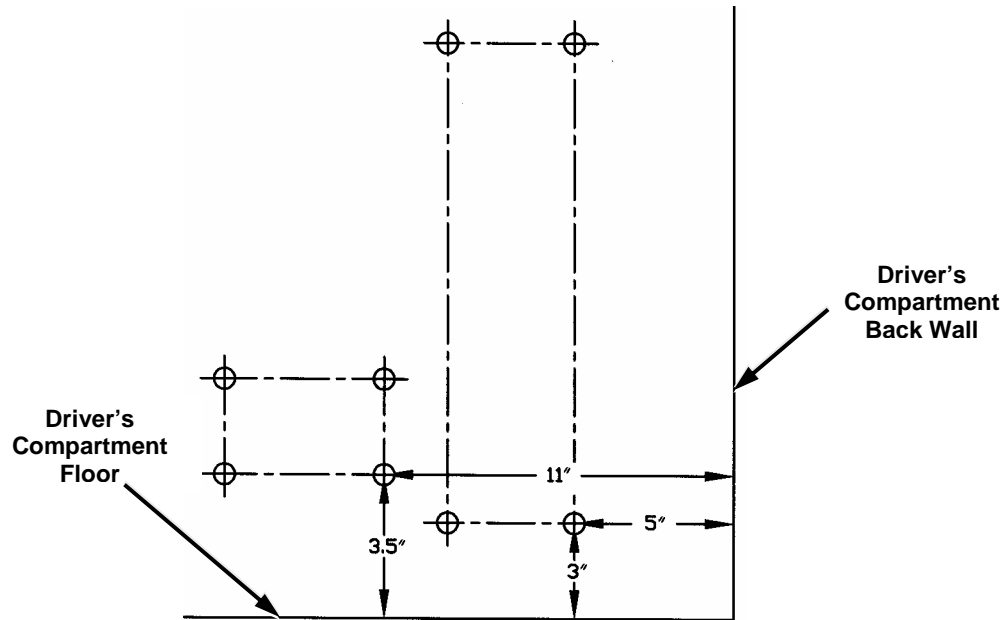

Figure 3-2. New Installation Holes.

b. NBC Installation:

1. Install left seatbelt in new hole from step a.8 above per TM 5-2350-262-20-2, Seatbelt Assembly Replacement.



Figure 3-3. New Locations on Driver's Compartment Back Wall.

2. Install the NBC system equipment, electrical components, hoses, air purifier and heater per TM 5-235-262-20-2, Section XIV, Air Purifier Installation, at new locations in holes per Figure 3-2.
3. Install driver's seat per TM 5-2350-262-20-2.
4. Install the Crew Cooling System (CCS), following instructions beginning at Chapter 2, Section III, step b.

By Order of the Secretary of the Army:

Official:

SANDRA R. RILEY
*Administrative Assistant to the
Secretary of the Army*

PETER J. SCHOOMAKER
*General, United States Army
Chief of Staff*

0531411

DISTRIBUTION: To be distributed in accordance with the Initial Distribution Number (IDN) 256841, requirements for MWO 5-2430-262-35-2

PIN: 082892-000